







KEY TO INSTRUMENTATION

-  Clay Paky Sharpy (Vector Mode)
Total: 13
300w
-  Vari-Lite 500TD
Total: 13
1200w
-  Vari-Lite 3500 Spot
Total: 7
1200w
-  Vari-Lite 3500 Wash
Total: 2
1650w
-  Martin Atomic 3000 DMX (4 Channel)
Total: 3
300w
-  ETC Desire D60 Lustr+ (Direct Mode)
Total: 18
200w
-  MDG Atmosphere
Total: 2
715w

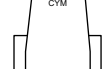
REV	REVISION	DATE

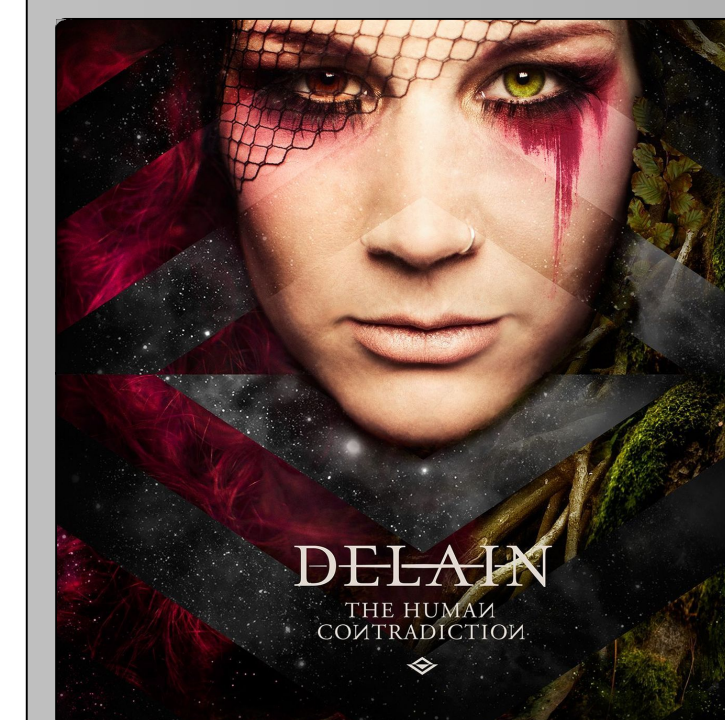

DELAIN Napalm Records

Misshapen Tour
2016

Alex Stevens
Lighting Design

THIS DRAWING REPRESENTS VISUAL CONCEPTS AND CONSTRUCTION SUGGESTIONS ONLY. IT DOES NOT REPLACE THE KNOWLEDGE AND ADVICE OF A LICENSED STRUCTURAL ENGINEER. THE DESIGNER IS UNQUALIFIED TO DETERMINE THE STRUCTURAL APPROPRIATENESS OF THIS DESIGN AND WILL NOT ASSUME RESPONSIBILITY FOR IMPROPER ENGINEERING OR USE.

SCALE:	1 1/2"=1'-0"	PLATE 1 OF 6
DRAWN BY:	Alex Stevens	
CREATED:	10/17/2015	
REVISED:	11/1/2015	
FILE:	Delain-Misshapen Tour Plot.rvt	

Overview

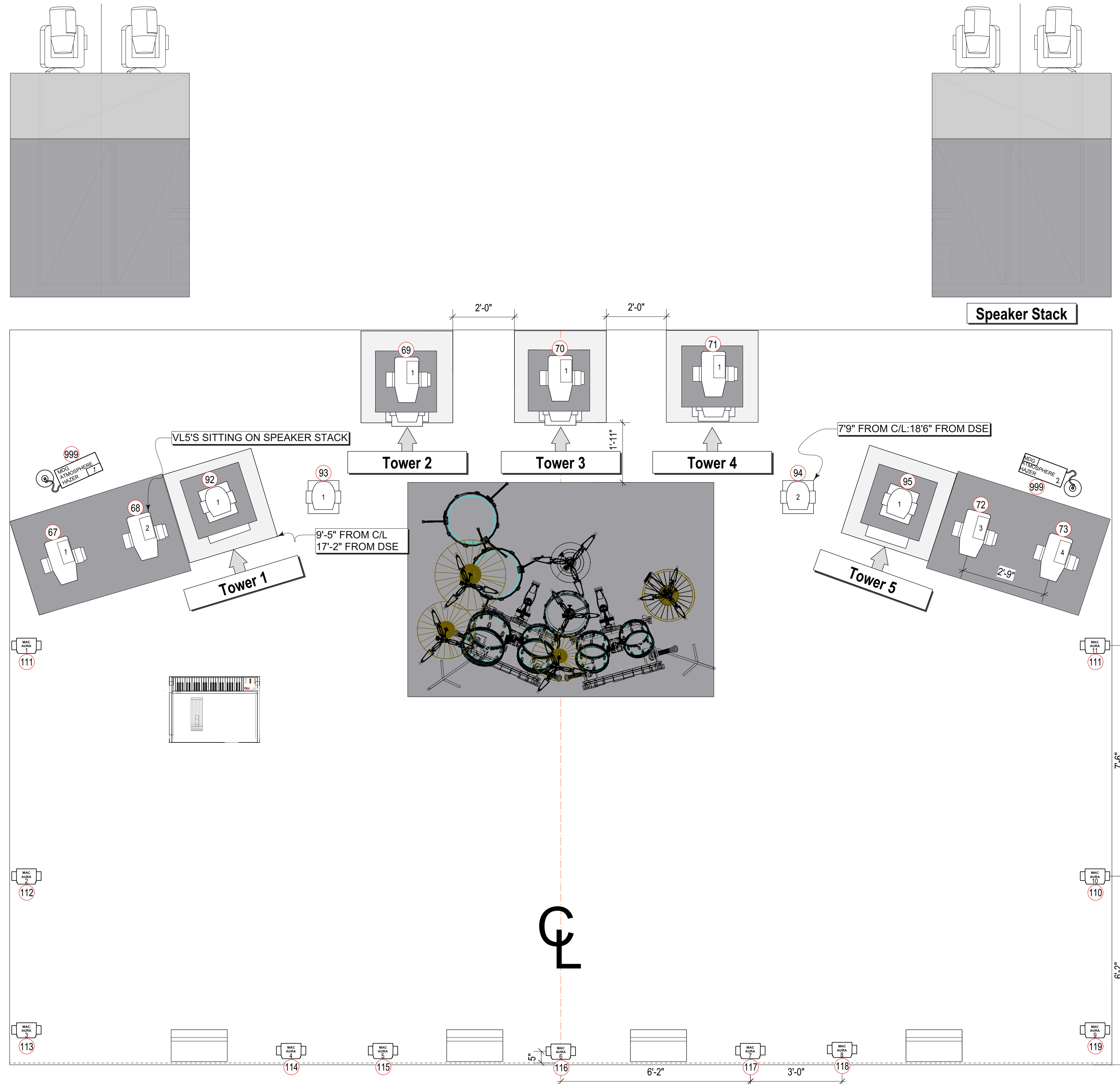

KEY TO INSTRUMENTATION

- Martin Mac Aura (Standard Mode)
x11
260w
- Clay Paky Sharpy (Vector Mode)
x10
300w
- Vari-Lite 500TD
x7
1200w
- Martin Atomic 3000 DMX (4 Channel)
x8
3000w

LEGEND

- Light Number
- Chan

REV	REVISION	DATE



DELAIN Napalm Records

Misshapen Tour
2016

Alex Stevens
Lighting Design

THIS DRAWING REPRESENTS VISUAL CONCEPTS AND CONSTRUCTION SUGGESTIONS ONLY. IT DOES NOT REPLACE THE KNOWLEDGE AND ADVICE OF A LICENSED STRUCTURAL ENGINEER. THE DESIGNER IS UNQUALIFIED TO DETERMINE THE STRUCTURAL APPROPRIATENESS OF THIS DESIGN AND WILL NOT ASSUME RESPONSIBILITY FOR IMPROPER ENGINEERING OR USE.

SCALE:	1/2"=1'-0"	PLATE
DRAWN BY:	Alex Stevens	
CREATED:	10/17/2015	
REVISED:	11/1/2015	
FILE:	Delain-Misshapen Tour-Plat.woc	

NOTES

- ALL AURA AND SHARPY TAILS FACE UPSTAGE
- ALL VL500 TAILS FACE UPSTAGE

Deck Package

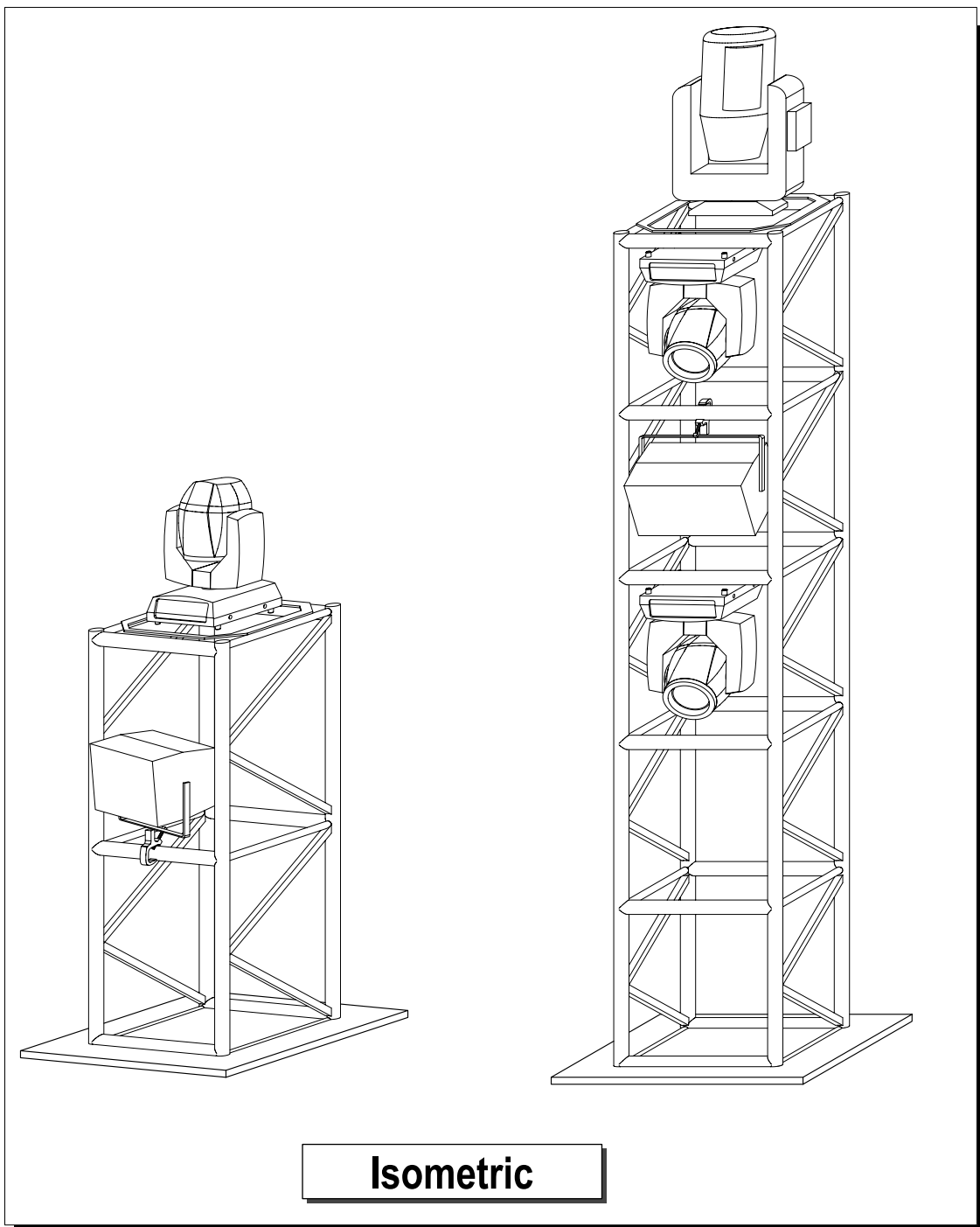

Isometric

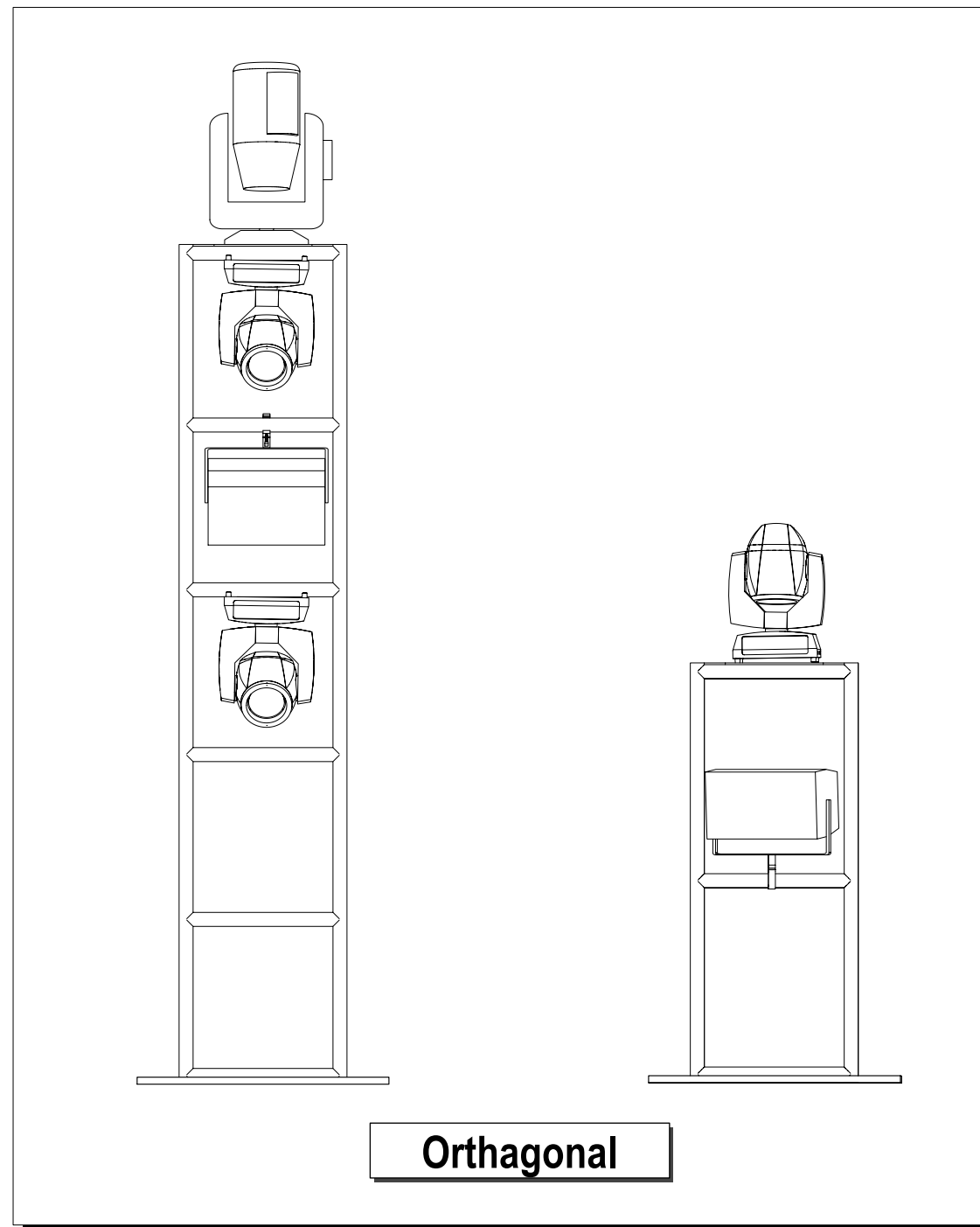

Orthogonal

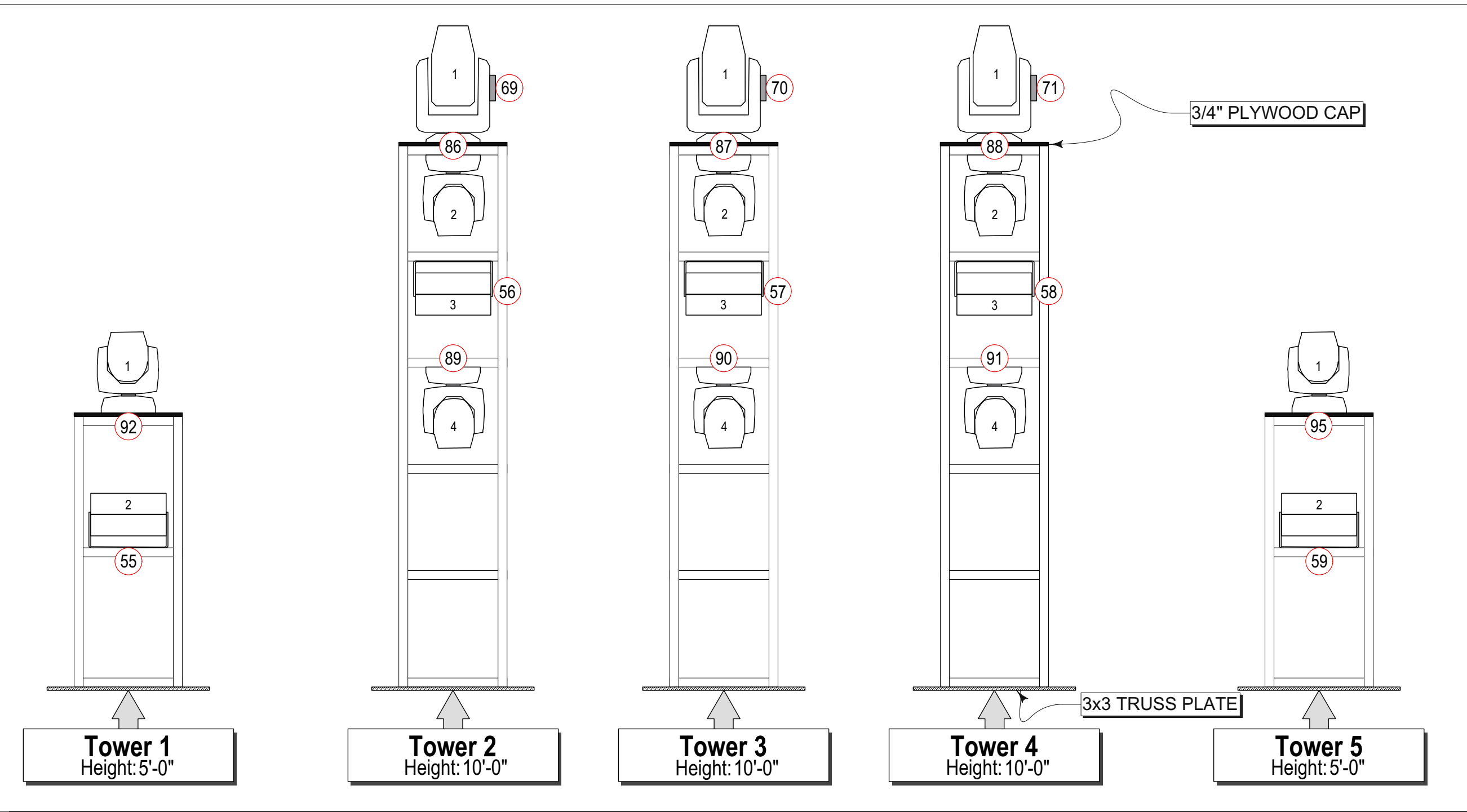

NOTES

- ALL SHARPY SCREENS FACE DOWNSTAGE
- ALL VL500 SCREENS FACE STAGE RIGHT

KEY TO INSTRUMENTATION

- Clay Paky Sharpy (Vector Mode)
x8
300w
- Vari*Lite 500TD
x3
1200w
- Martin Atomic 3000 DMX (4 Channel)
x5
3000w

LEGEND

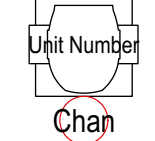

REV	REVISION	DATE



DELAIN

Misshapen Tour
2016

Napalm Records

Alex Stevens
Lighting Design

THIS DRAWING REPRESENTS VISUAL CONCEPTS AND CONSTRUCTION SUGGESTIONS ONLY. IT DOES NOT REPLACE THE KNOWLEDGE AND ADVICE OF A LICENSED STRUCTURAL ENGINEER. THE DESIGNER IS UNQUALIFIED TO DETERMINE THE STRUCTURAL APPROPRIATENESS OF THIS DESIGN AND WILL NOT ASSUME RESPONSIBILITY FOR IMPROPER ENGINEERING OR USE.

SCALE: 1/2"=1'-0"
 DRAWN BY: Alex Stevens
 CREATED: 10/17/2015
 REVISED: 11/1/2015
 FILE: Delain-Misshapen Tour Plot.vwx

PLATE
3
OF 6

Tower Detail

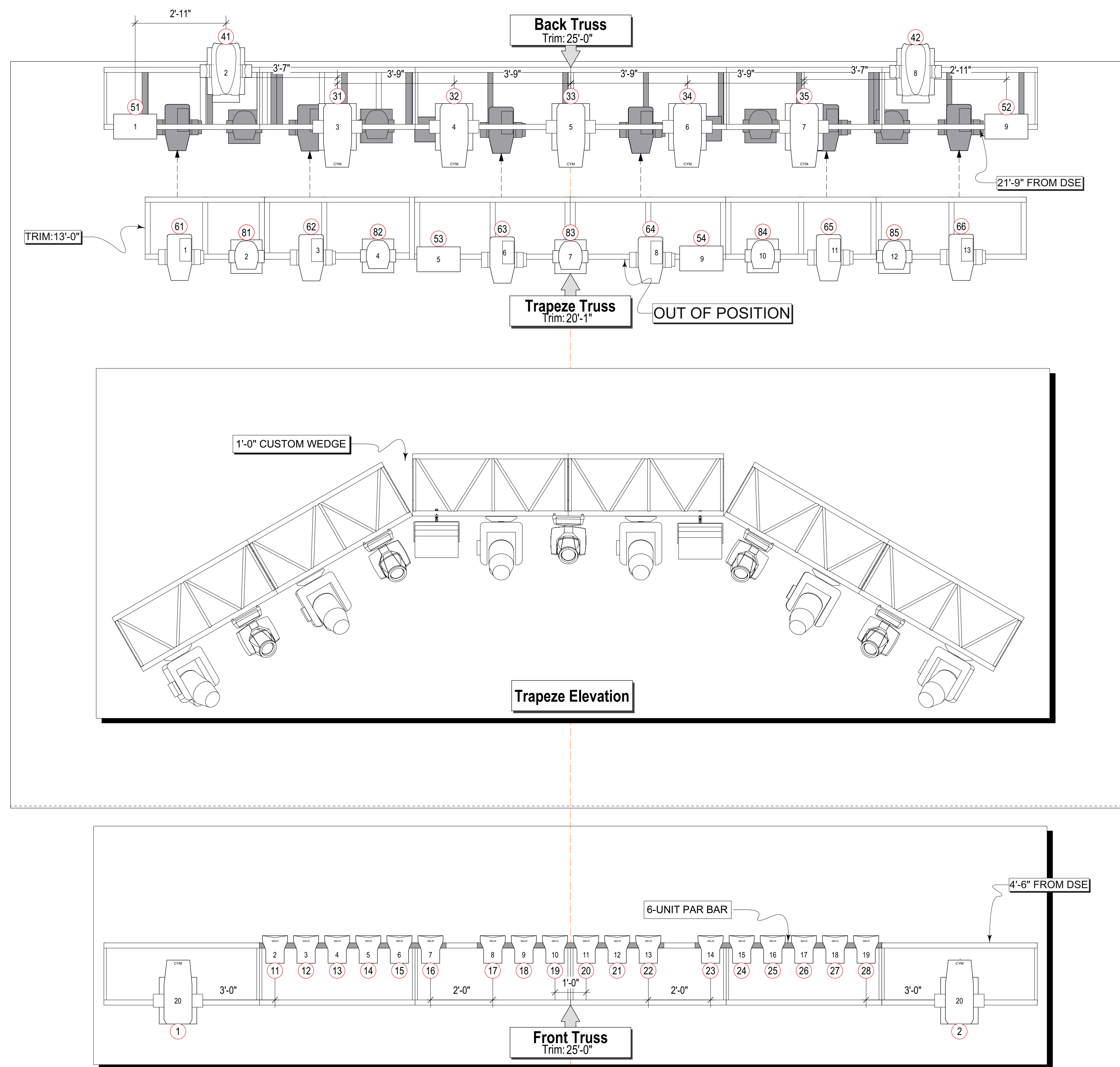

KEY TO INSTRUMENTATION

- Clay Paky Sharpys (Vector Mode)
Total=15
300w
- Vari*Lite 500TD
Total=13
1200w
- Vari*Lite 3500 Spot
Total=7
1200w
- Vari*Lite 3500 Wash
Total=2
1650w
- Martin Atomic 3000 DMX (4 Channel)
Total=9
3000w
- ETC Desire D60 Lustr+ (Direct Mode)
Total=18
1200w

LEGEND

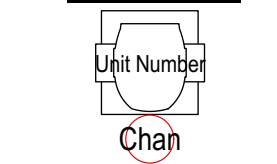

REV	REVISION	DATE

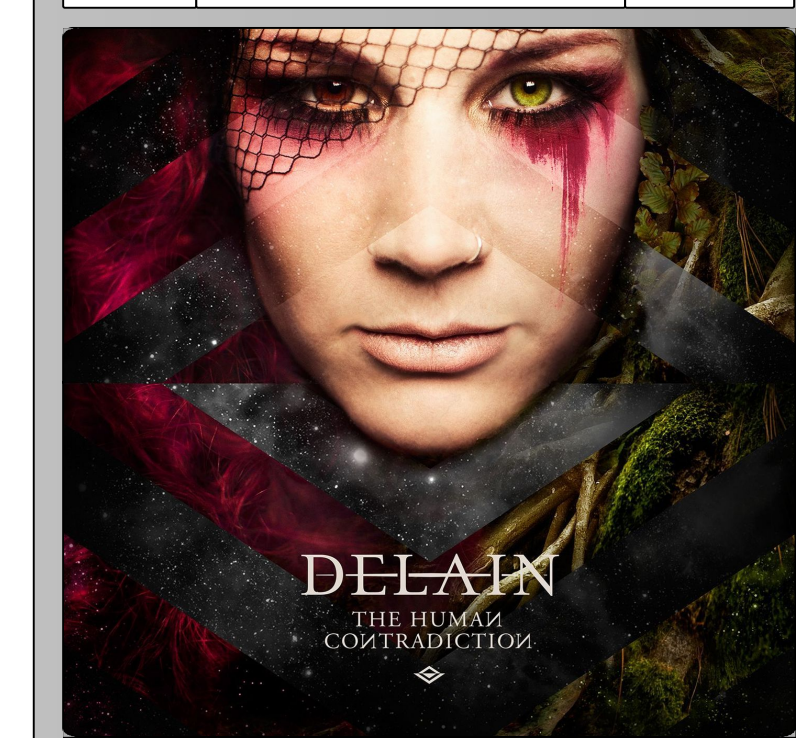

DELAIN Napalm Records

Misshapen Tour
2016

Alex Stevens
Lighting Design

THIS DRAWING REPRESENTS VISUAL CONCEPTS AND CONSTRUCTION SUGGESTIONS ONLY. IT DOES NOT REPLACE THE KNOWLEDGE AND ADVICE OF A LICENSED STRUCTURAL ENGINEER. THE DESIGNER IS UNQUALIFIED TO DETERMINE THE STRUCTURAL APPROPRIATENESS OF THIS DESIGN AND WILL NOT ASSUME RESPONSIBILITY FOR IMPROPER ENGINEERING OR USE.

SCALE:	1/2"=1'-0"
DRAWN BY:	Alex Stevens
CREATED:	10/17/2015
REVISED:	11/1/2015
FILE:	Delain-Misshapen Tour Plat.woc

PLATE
4
OF 6

NOTES
-ALL 3500, SHARPY, AND VL500 TAILS FACE UPSTAGE

Overhead

KEY TO INSTRUMENTATION

REV	REVISION	DATE



DELAIN

Napalm Records

Misshapen Tour
2016

Alex Stevens
Lighting Design

THIS DRAWING REPRESENTS VISUAL CONCEPTS AND CONSTRUCTION SUGGESTIONS ONLY. IT DOES NOT REPLACE THE KNOWLEDGE AND ADVICE OF A LICENSED STRUCTURAL ENGINEER. THE DESIGNER IS UNQUALIFIED TO DETERMINE THE STRUCTURAL APPROPRIATENESS OF THIS DESIGN AND WILL NOT ASSUME RESPONSIBILITY FOR IMPROPER ENGINEERING OR USE.

SCALE: 1/2"=1'-0"
 DRAWN BY: Alex Stevens
 CREATED: 10/17/2015
 REVISED: 11/1/2015
 FILE: Delain-Misshapen Tour Plot.vswx

PLATE
5
OF 6



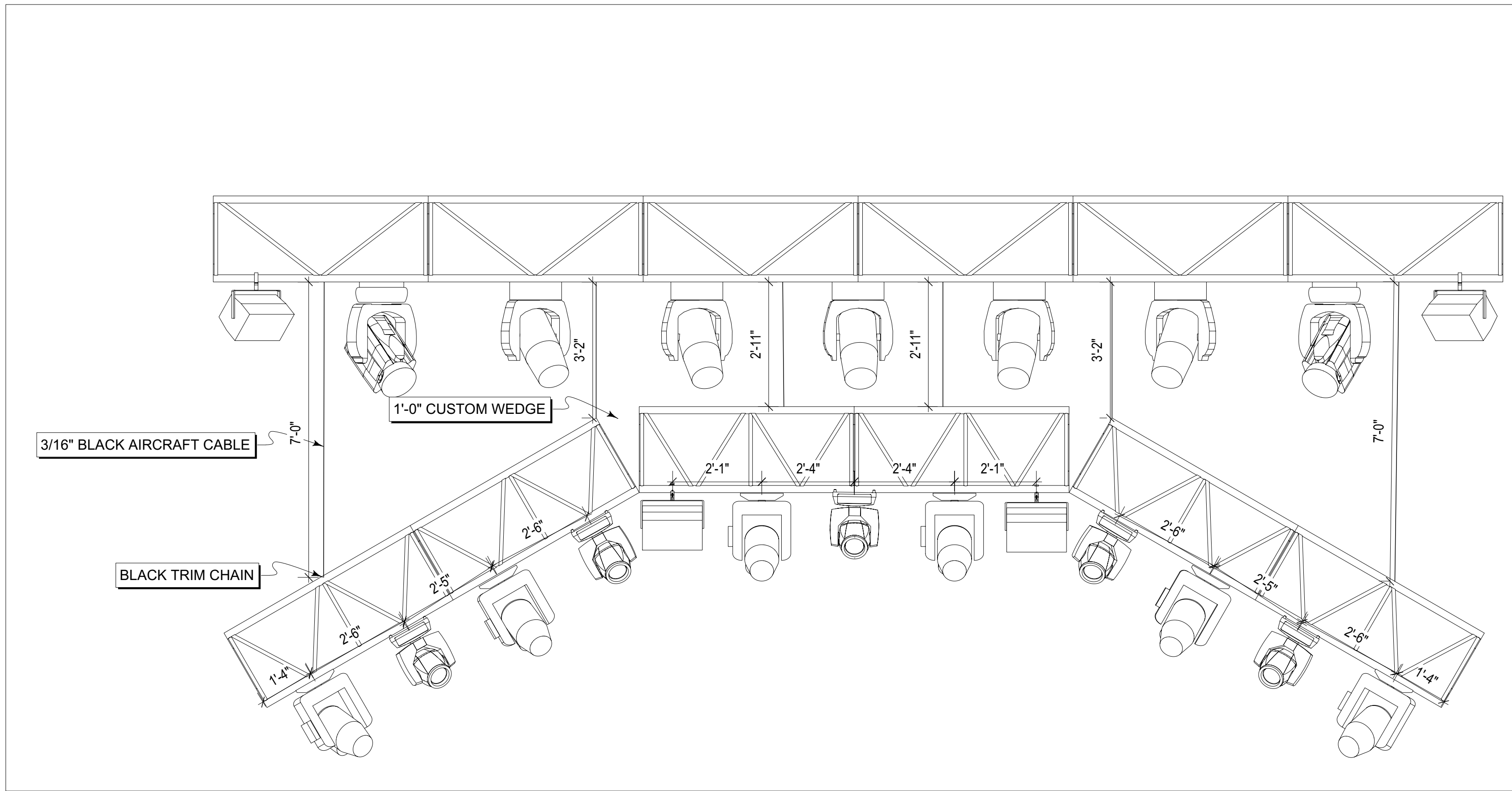

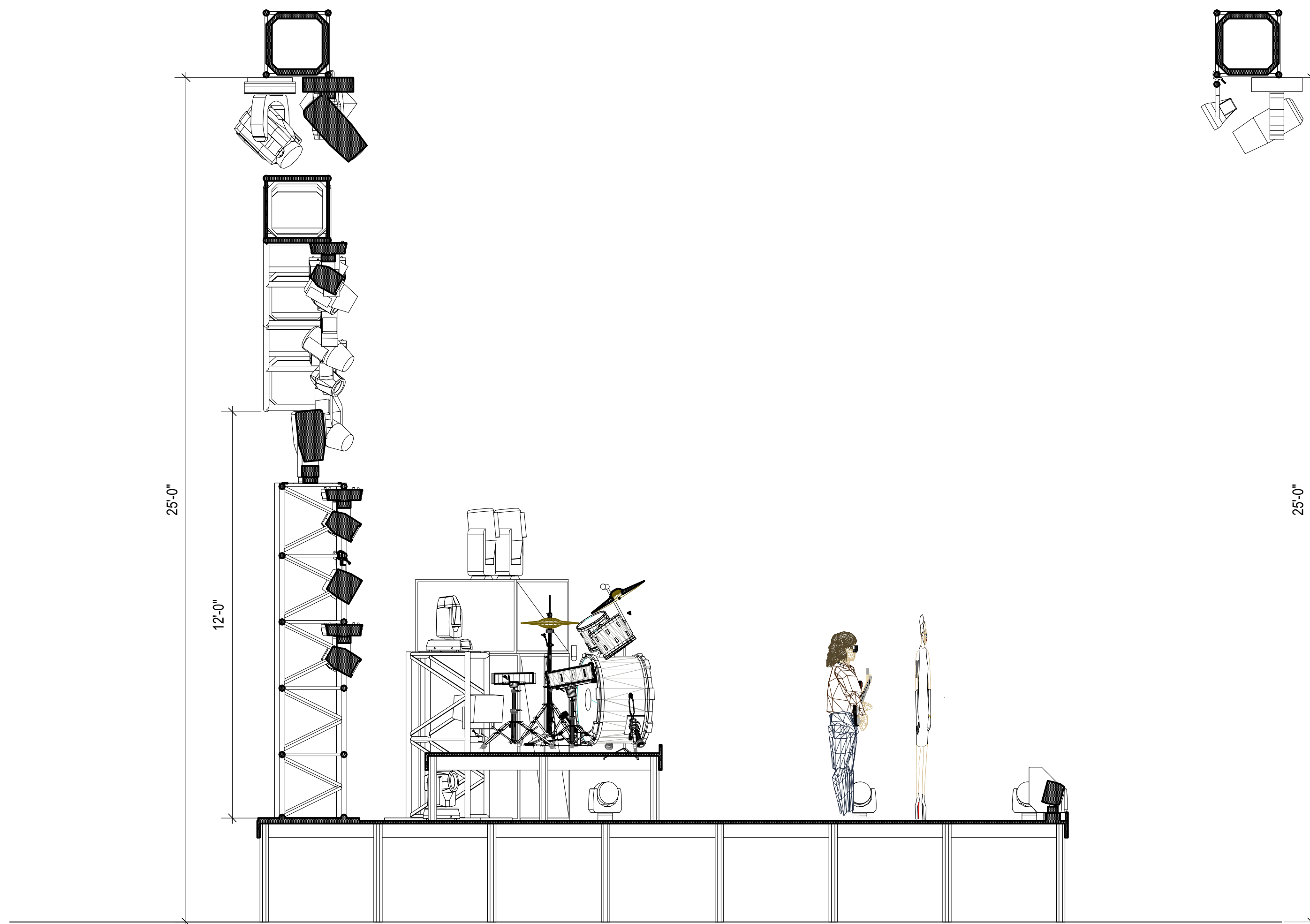
Hanging Elevation



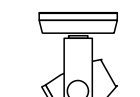

6 SL Section
6 Scale: 3/8" = 1'-0"

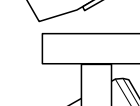
KEY TO INSTRUMENTATION

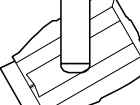
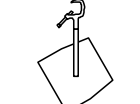
-  Clay Paky Sharpie (Vector Mode)
x5
300w
-  Vari*Lite 500TD
x6
1200w
-  Vari*Lite 3500 Spot
x7
1200w
-  Vari*Lite 3500 Wash
x2
1650w
-  Martin Atomic 3000 DMX (4 Channel)
x4
3000w
-  ETC Desire D60 Lustr+ (Direct Mode)
x18
320w

REV	REVISION	DATE
REV	REVISION	DATE
REV	REVISION	DATE
REV	REVISION	DATE

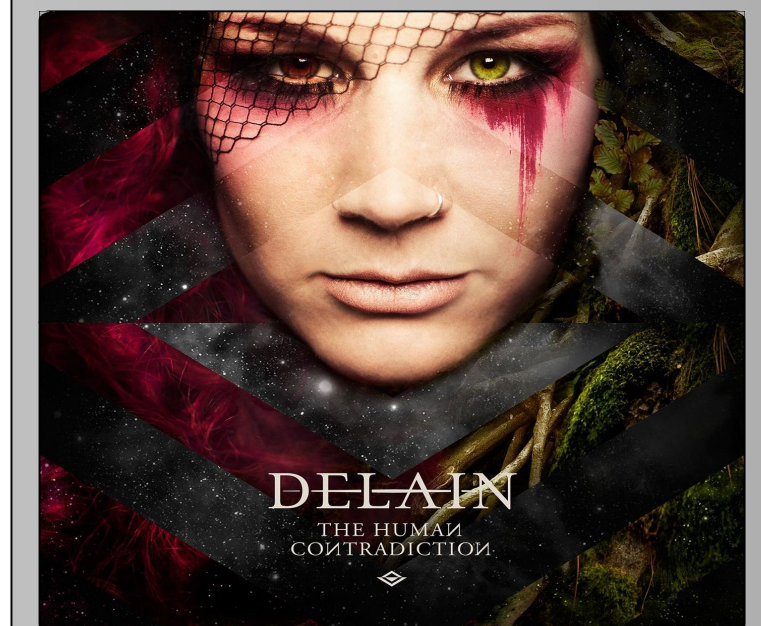

DELAIN

Misshapen Tour
2016

Napalm Records

Alex Stevens
Lighting Design

THIS DRAWING REPRESENTS VISUAL CONCEPTS AND CONSTRUCTION SUGGESTIONS ONLY. IT DOES NOT REPLACE THE KNOWLEDGE AND ADVICE OF A LICENSED STRUCTURAL ENGINEER. THE DESIGNER IS UNQUALIFIED TO DETERMINE THE STRUCTURAL APPROPRIATENESS OF THIS DESIGN AND WILL NOT ASSUME RESPONSIBILITY FOR IMPROPER ENGINEERING OR USE.

SCALE:	3/8" = 1'-0"	PLATE 6 OF 6
DRAWN BY:	Alex Stevens	
CREATED:	10/17/2015	
REVISED:	11/1/2015	
FILE:	Delain-Misshapen Tour Plot.vswx	

SL Section